

# OPTIMISE YOUR CLEANING PROCESSES WITH IMPROVED TECHNOLOGY





# THE GHP SELF-PRIMING PUMP

— OPTIMISED FOR EVEN MORE EFFICIENT PERFORMANCE

Grundfos' new range of GHP (Grundfos Hygienic self-Priming) pumps takes efficiency and durability to new levels in sanitary processes. The pumps are based on the well-known HILGE technology and are further optimised to offer reliable operation even under the tough conditions encountered in cleaning processes.

The single-stage self-priming GHP pumps combine the best of the F&B-HYGIA end-suction pumps with the reliable HILGE technology. The result is an optimised pump range that comes with increased efficiency compared to traditional side-channel pumps and can be counted on for long operational life.

## ONE PUMP – MORE APPLICATIONS

Due to the robust construction of the new GHP pumps they are able to handle liquids with a high content of air as is the case in CIP return systems. In effect, this means that the same pump can be used for product conveyance as well as for the

cleaning processes. Compared to side-channel pumps, GHP pumps are also less sensitive to handling products containing particles.

## LOW NOISE OPERATION

The GHP pumps feature a new, unique hydraulic technology that allows the impeller to be adjusted to accommodate exact duty-point requirements. This translates into a noise level significantly lower than compared to traditional side-channel pumps.

## SPECIALLY DESIGNED FOR SANITARY APPLICATIONS

The all-stainless steel GHP pumps have been specially designed for trouble-free operation in sanitary processes such as:

- > Cleaning processes (CIP return)
- > Evacuation of tanks and pipes
- > Pumping liquids with a high gas content
- > Pumping liquids in Food and Beverage industries.



## PERFORMANCE CURVE

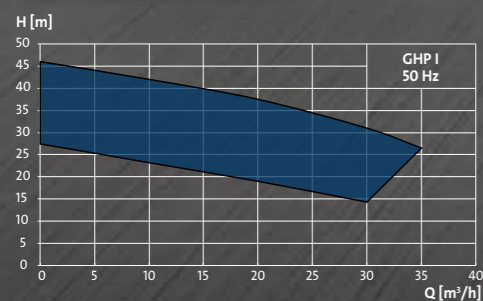

## FEATURES AND BENEFITS

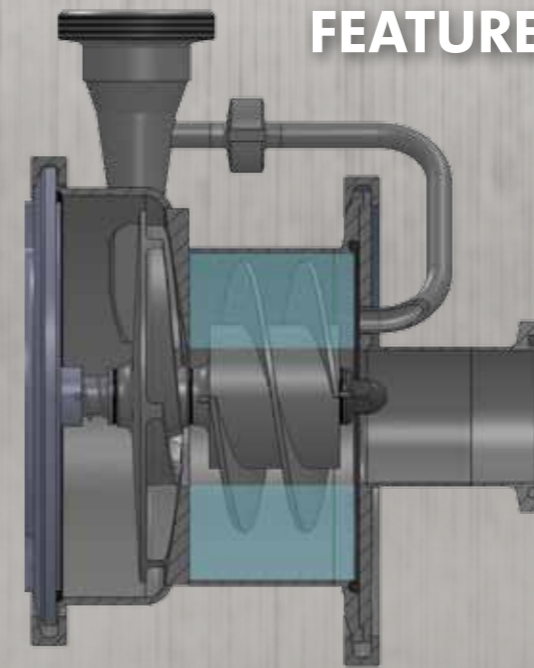

### PRECISION DESIGN

Optimised hydraulics for high efficiency and low noise emission

### HIGH-QUALITY MATERIALS

Extremely reliable

### TRIMMED IMPELLER DIAMETERS

Efficient and accurate performance

### INBOARD SHAFT SEAL

Easily cleanable

### SELF-PRIMING

Exceptional self-priming capabilities

## ALL-STAINLESS STEEL CONSTRUCTION

The GHP pumps are made entirely from stainless steel, chosen specifically for its hygienic properties. To ensure a smooth, pore-free finish, the casings are made from cold-rolled, deep-drawn stainless steel 1.4404/1.4435 (AISI 316L). Many of the parts – particularly the wear parts – are identical to those used in the various HYGIA ranges, which greatly simplifies spare part handling.

## SHAFT SEALS

The GHP self-priming pumps are available with various shaft seal options to accommodate different liquids and applications. All options use single inboard seals to maintain the optimum position in the liquid. Choices include:

- > Construction: Single or single flush mechanical shaft seals
- > Standard seal face material: Carbon/stainless steel and SiC/SiC
- > Standard O-ring material: EPDM (FDA compliant)

Additional constructions and designs are available on request.

## CERTIFICATION COMPLIANCE

The GHP pumps are CIP/SIP capable in accordance with DIN EN 12462 performance criteria. All wet end parts meet the Qualified Hygienic Design (QHD) standards.

## DESIGN VARIATIONS

Variation	Description
GHP	<ul style="list-style-type: none"> <li>&gt; Horizontal installation on motor foot</li> <li>&gt; Horizontal installation on combi foot</li> <li>&gt; Horizontal installation on stainless steel foot</li> <li>&gt; Mobile, on stainless steel trolley</li> </ul>
GHP SUPER	<ul style="list-style-type: none"> <li>&gt; Horizontal installation with stainless steel motor shroud on combi foot</li> <li>&gt; Horizontal installation with stainless steel motor shroud on stainless steel foot</li> <li>&gt; Mobile, with stainless steel motor shroud on stainless steel trolley</li> </ul>

## TECHNICAL DATA

GHP	
Flow:	35 m³/h
Head:	45 m
Liquid temperature:	95 °C, 140 °C (SIP)
Single-stage self-priming pump	PN 16



## ABOUT GRUNDFOS

Grundfos has developed and produced high-quality industrial pumps for more than half a century. Every solution is backed by decades of solid know-how and a desire to push the boundaries for innovative pump technology – and naturally provides reliable, efficient performance.

As a truly global company, Grundfos offers you easy access to sales, support and service professionals in 56 countries around the world. Wherever you are based, extensive pump and pump application know-how will be available to you in your local language.

Explore the complete Grundfos portfolio at [www.grundfos.com](http://www.grundfos.com).